

Short Instructions

MiniTest 7200 FH / 7400 FH

1.1 Gauge description

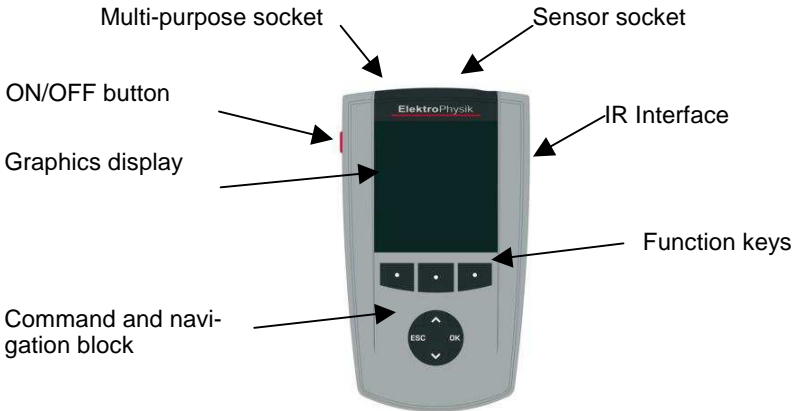

Use the **ON/OFF button** to switch the gauge ON or OFF. If you press ON/OFF button and ESC simultaneously, the initializing procedure will be performed.

The **Function keys** may assume different functions according to the menu being active. Their current properties are displayed in the line upper to the Function keys.

The **command and navigation key block** may also assume different functions:

- Press OK to confirm settings, store values or select menu items.
- Press ESC to abort actions or to quit submenus.
- Use ARROW keys to navigate through the menu or change settings.
- If the alphanumerical block has been activated, OK and ESC keys also assume navigation functions.

The gauge features a context-sensitive on-line help. According to screen, press the left function key "Help" to get access to the direct help.

2. The User Menu

The numerous gauge functions may be accessed via the hierarchical structuring of the user menu. Press function key **“Main Menu”** in order to get access to the menu system.

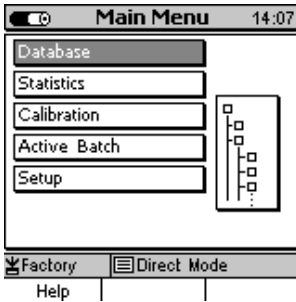

Select an item from the Main Menu (e.g. Setup) and press OK to confirm. You will go to a submenu.

Use the arrow keys to select the requested item (e.g. Date / Time) and press OK to confirm. To go back to the previous menu level press ESC.

According to selected submenu you can

- View settings (e.g. Gauge specs = Gauge specifications)
- Select preset parameters
- Make numerical or alphanumeric entries

2.1 Alphanumerical Entries (on MiniTest 7400 FH)



For alphanumeric entries you can use as many as 15 characters for entering a name. ESC and OK assume navigation functions to the left or right. Choose your character via the alphanumeric block. Your selection will be automatically accepted after the previously specified period of time. This period of time can be set under User Preferences in the “Entry accepted” option. Complete your entry by pressing Function key “Ready” and then confirm “Save changes?” by pressing OK.

3. Insert Batteries and connect Sensor

3.1. Insert batteries / storage batteries and connect sensor

- a) Take gauge and batteries from the carrying case.
- b) Push the battery compartment lid at the gauge bottom in arrow direction (as shown below)
- c) Insert batteries into the battery compartment. Respect polarities (as shown below).
- d) Close lid.

referring to b)

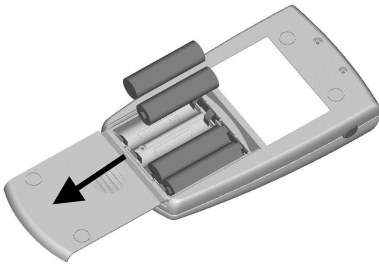

referring to c)

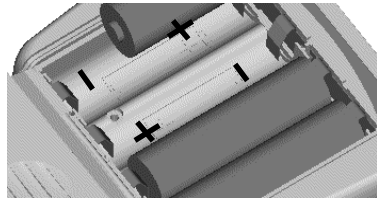

- e) Take requested sensor (FH4 or FH10) from the carrying case. Plug sensor into the socket on top of the base unit. Make sure the nib of plug is correctly inserted into the guide way of socket. The red marking at the probe plug must be positioned correctly to the red marking at the sensor plug.
- f) Fully engage the sensor plug into the sensor socket to the stop.

3.2 Switch ON and Take Readings

This setting can be made at initial use or as requested at any time.

Press the red ON/OFF button on the left side of gauge and ESC simultaneously to switch on and to go to initialization menu.

1. A banner appears with a language option.
Use arrow keys $\uparrow\downarrow$ to go to your requested language option.
Press OK to confirm or ESC to abort.
2. On display appears "Total Reset". A Total Reset restores factory settings.
To abort Total Reset, press Function key "No".

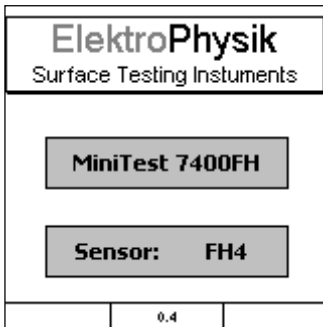

- a) **Start Screen** appears showing company logo, gauge version and sensor type that is currently connected (see illustr. on the left.)
- b) After approx. 2 seconds, the gauge switches automatically into measure mode and is ready to take readings. The **Measure Screen** will appear without any reading being shown.
- c) At initial switch-on the gauge is in "Direct Mode". For this mode, the factory calibration is preset. Please check whether the target ball size as adjusted matches your application.

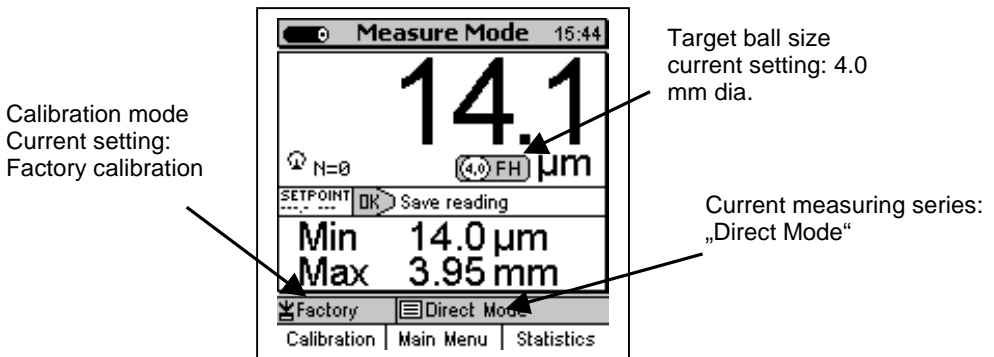

- a) The factory calibration is for quick and easy measurement when larger measuring errors are acceptable. For other calibration methods please refer to section 6.2.
- b) For measurement, please use the sensor stand supplied with the gauge. Place the measuring object on the sensor. Place the target ball on the opposite side. For measuring hollow parts, place the ball inside the sample. Equipped with a strong permanent magnet, the sensor attracts the target ball and holds it exactly over its sensor tip. Hold the measuring object in rectangular position to the sensor and move it smoothly over the sensor. Press OK to store the reading into memory. Press Function key "Statistics" to view readings and the numerical statistics.

For measuring large-sized sheeting material or large hollow parts, place the sensor on the surface of sample. The target ball is placed on the opposite side near the sensor. Keep the sensor in rectangular position to the surface and move it across the surface of sample.

Short Instructions MiniTest 7200 FH / 7400 FH

CALIBRATE

Factory Calibration

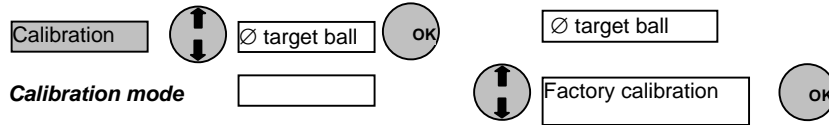

Signs and Symbols:

Calibration

Function key



Navigation block

∅ target ball

Display

Zero-Point Calibration

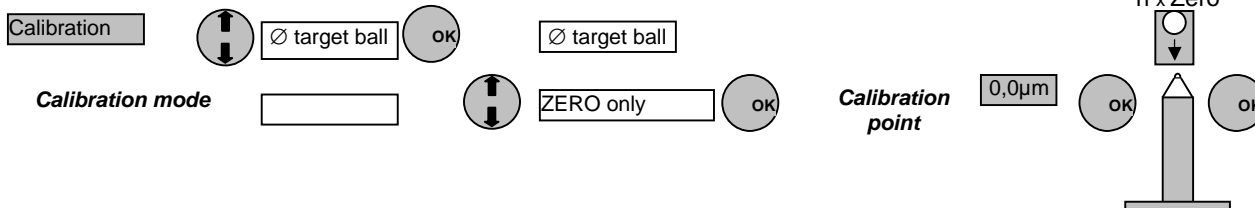

Multi-Point Calibration (ZERO + 1 Point)

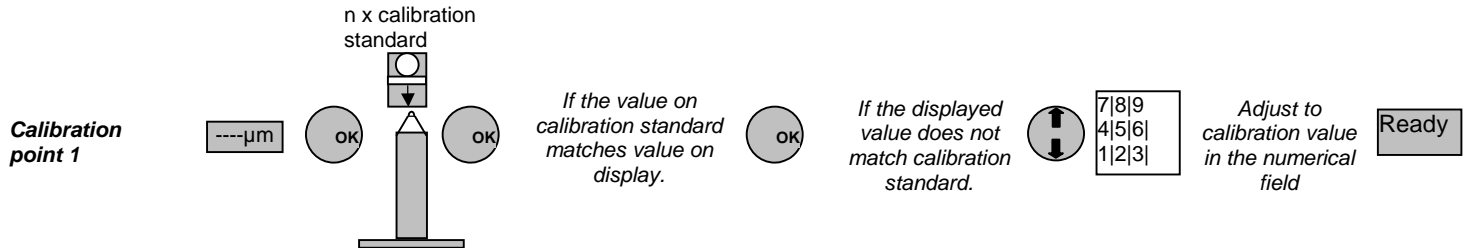
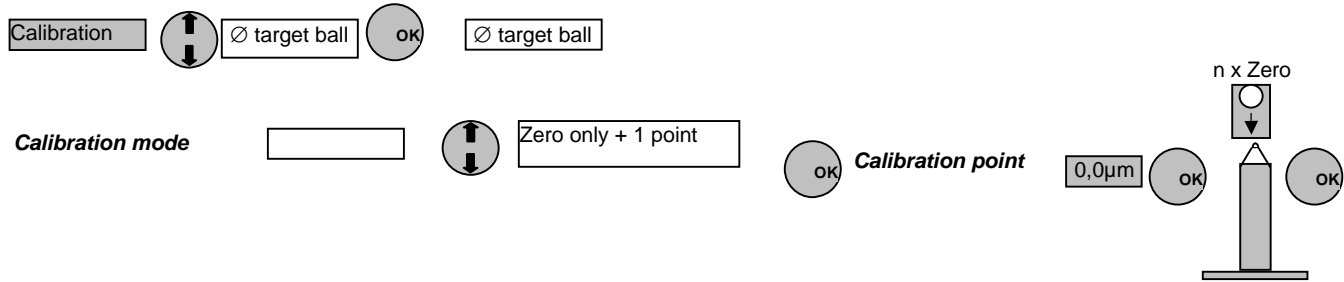

For multi-point calibration by means of various standards please follow the same procedure.

DELETE FUNCTIONS

With MiniTest 7200 FH in Measuring Mode

Delete one single reading

Select
reading to be
deleted

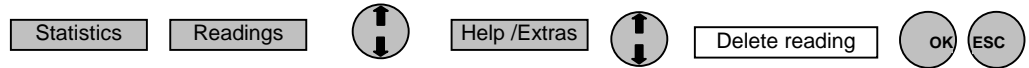

Delete all readings

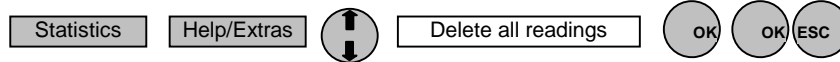

With MiniTest 7400 FH in Measuring Mode

Delete one single reading

Select value
to be deleted.



Delete all readings of active batch



Delete a Batch

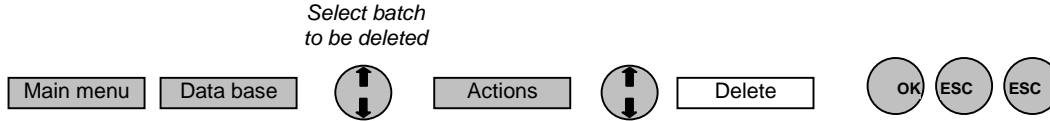

User Preferences

Measuring mode

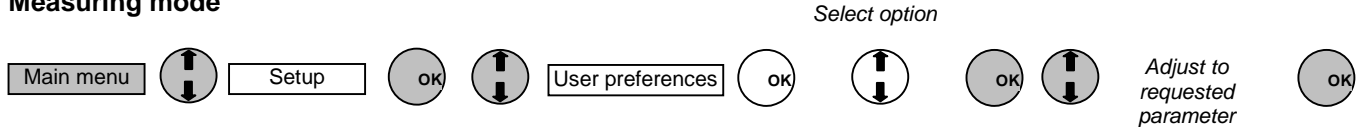

Configuration

Measuring mode

